



## SAFEVIEW™ STATUS

GREEN LED  NORMAL OPERATION		
Coax Link	Off	No power
	Blink	No data link
	On	Full data link
Ethernet Link/Activity	Off	No network connection
	On	Ethernet link active
	Blink	Network activity
POE over Coax	Off	HIGHWIRE Powerstar not detected
	On	POE over Coax enabled
POE to Camera	Off	POE device not detected
	On	POE enabled to device
Maximum POE Power Available	Off	No POE available
	On	5W to 25W as indicated
	Blink	Less than 5W available

WARNING INDICATORS		
RED LED  ORANGE LED 		
Coax Link	Red/ Orange	Data rate <100%
Ethernet Link/Activity	Red	10Base-T connection
POE over Coax	Red	(1 Blink) Low voltage
	Red	(2 Blinks) Short circuit
	Red	(3 Blinks) Overload
POE to Camera	Orange	Low voltage
	Red	(Blink), No POE
	Red	POE disconnected Overload
Maximum POE Power Available	Orange	(Flashing) Near power limit
	Red	At power limit

## SAFEVIEW™ NOTES

Always check the SAFEVIEW™ status LEDs and power gauge on installation. This displays the link status and the actual power available for the powered device, measured for the actual cable type, length, quality and power source. It is calculated automatically on connection.

If installing a PTZ IP camera, or any other device whose power requirement changes during operation, check the SAFEVIEW™ LEDs when the device is drawing maximum power.

For maximum POE over Coax, use the recommended Veracity 57V PSU (VPSU-57V-800) to power the Base device. If more power is required than the cable can transmit, use a 57V PSU to power the HIGHWIRE Powerstar Camera device.

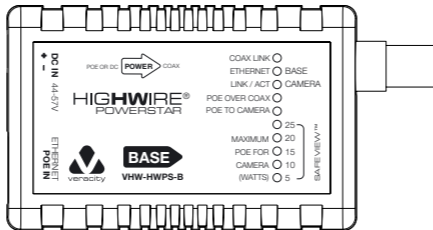

## SURGE PROTECTION

### Surge Protection

All Veracity products have been independently tested to verify their resilience to the stringent immunity levels of international standards. Users should note that no electronic equipment can be guaranteed to be completely protected at levels beyond the defined standard; therefore product warranty cannot include damage to products which has been caused by surges exceeding those of the standards specified, for example lightning strike activity.

It is the user's responsibility to implement relevant surge protection measures, as appropriate to the installation. This may include the fitting of additional surge protection devices where required.

### Veracity UK Ltd

Prestwick International Aerospace Park, 4 Dow Road, Prestwick, KA9 2TU. UK

Veracity's Authorised Representative in the EU (as required by EU law for CE marked goods) is: Comply Express Unipessoal Limitada, StartUp Madeira, EV141, Campus da Penteada, 9020 105 Funchal, Portugal.

## FCC CERTIFICATION

### This device complies with Part 15 of the FCC Rules.

Operation is subject to the following two conditions: (1) this device may not cause harmful interference, and (2) this device must accept any interference received, including interference that may cause undesired operation.

*NOTE: This equipment has been tested and found to comply with the limits for a Class A digital device, pursuant to Part 15 of the FCC Rules. These limits are designed to provide reasonable protection against harmful interference when the equipment is operated in a commercial environment.*

*This equipment generates, uses, and can radiate radio frequency energy and, if not installed and used in accordance with the instruction manual, may cause harmful interference to radio communications. Operation of this equipment in a residential area is likely to cause harmful interference in which case the user will be required to correct the interference at their own expense.*



© Veracity UK Ltd 2021 QSG DV2.2 EN  
HIGHWIRE Powerstar is a registered trademark of Veracity UK Ltd

VHW-HWPS-B, VHW-HWPS-C

## QUICKSTART GUIDE

ETHERNET & POE OVER COAX ADAPTOR

**HIGHWIRE®**  
POWERSTAR



## HIGHWIRE POWERSTAR DIMENSIONS

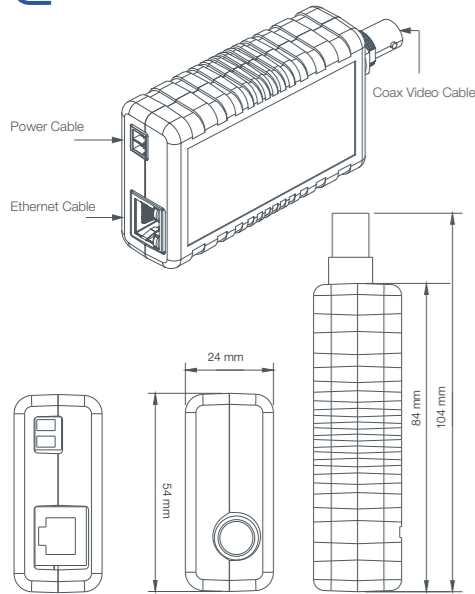

## HIGHWIRE POWERSTAR CABLE CONNECTION

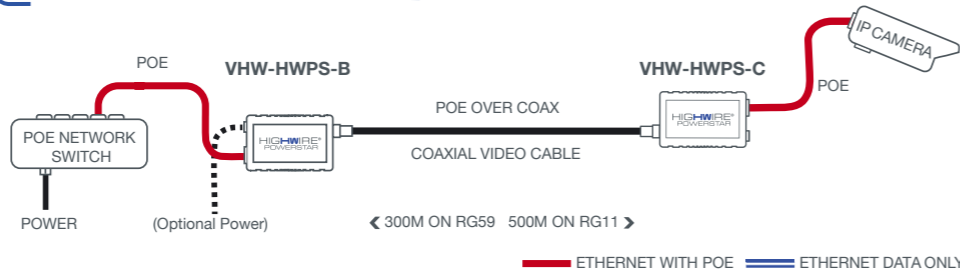

- HIGHWIRE Powerstar Base and Camera devices are used together to adapt conventional Ethernet to a signal, with POE, that can be carried by coaxial video cables such as RG59.
- HIGHWIRE Powerstar makes it possible to swap installed analogue cameras for high resolution digital IP cameras without the expense of replacing existing coax cabling.

- The Base and Camera devices are used in pairs, with one at each end of the coax cable. Once powered, they provide a full-duplex 100Mbps data link, with POE, across the coaxial video cable, delivering standard 100Base-TX Ethernet at each end.
- The HIGHWIRE Powerstar Base device may be powered by a POE switch or, for maximum power delivery, by a Veracity 57V DC power supply.

## MOUNTING HIGHWIRE

- The HIGHWIRE unit should only be installed indoors or in an appropriately rated enclosure.
- Both Base and Camera devices should be securely mounted and should not be supported by the attached cables.
- Veracity's Wall Mount Bracket, product code VHW-WMB, can be used for bolting the device to a wall or structure.
- Veracity's Rackmount Bracket, product code VHW-1U, allows installation of up to eight HIGHWIRE devices in 1U of a 19-inch rack.
- Veracity's DIN Rail Mount, product code VHW-DMB, mounts the device onto a DIN rail.

## POWER CONNECTION

- The HIGHWIRE Powerstar Base device may be powered through the RJ45 port by a POE switch (802.3af or 802.3at) or injector, but for

maximum power, a separate 57V DC PSU should be used (VPSU-57V-800). Other PSUs are available for powering multiple Base devices).

- Connect the 57V PSU using the detachable screw terminal connector, observing the correct +/- polarity. The POE input is disabled if the external PSU is connected.
- Once powered, the HIGHWIRE Powerstar Base device will automatically deliver POE over the coax to the HIGHWIRE Powerstar Camera device and from there to the IP camera or PD.

## HIGHWIRE CONNECTION

- Network communication over the HIGHWIRE to HIGHWIRE coax link is automatically established after power-up and is unrestricted and transparent to all network traffic.
- HIGHWIRE data links over coax are not compatible with legacy equipment such as analogue video amplifiers, baluns or interference filters.
- Only two devices should be connected, one at each end of the cable.

## OPTIONAL LOCAL POWER

- As an option, or for maximum possible power delivery to the powered device, the HIGHWIRE Powerstar Camera device may be powered locally at the camera end by an external 57V DC power supply (VPSU-57V-800).
- POE input from the coax is disabled if the external PSU is connected. In this case, a standard non-POE HIGHWIRE can be used at the Base end.

## ETHERNET CONNECTIONS

- Standard Ethernet cables may be used to connect the Base HIGHWIRE Powerstar to the switch and from the Camera HIGHWIRE Powerstar to the IP camera or other device.
- Both patch and crossover type Cat5e and Cat6 cables are supported.
- PD = Power Device