

ETHERNET & POE OVER COAX  
**HIGHWIRE**<sup>®</sup>  
 POWERSTAR  
 BASE 8

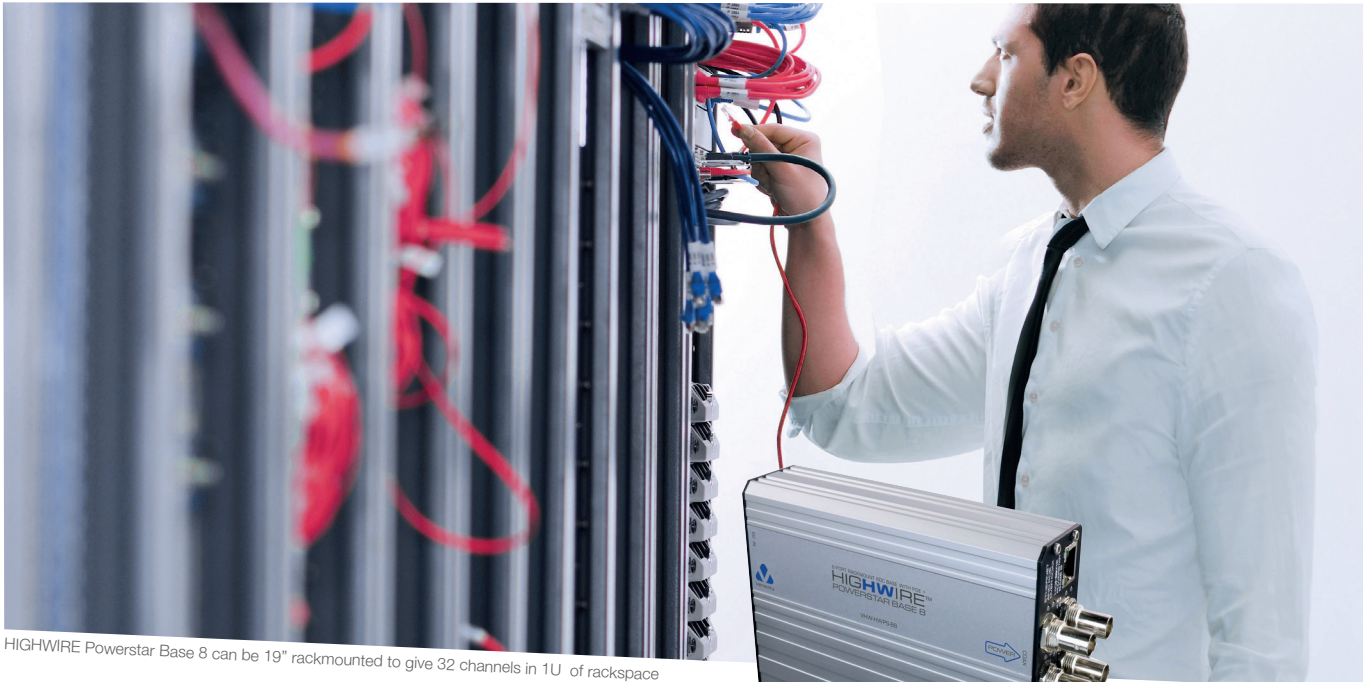

HIGHWIRE Powerstar Base 8 can be 19" rackmounted to give 32 channels in 1U of rackspace

## Multi-channel Ethernet and POE over legacy coax cable for easy upgrade to IP cameras

Four 8-channel Base devices provide 32 IP channels in 1U, with space for an optional 1U power supply and up to 25W POE per channel.

- | 8 channels per Base device, up to 32 channels in 1U
- | Full-duplex 100Base-TX performance on each coax link
- | Gigabit uplink port with fibre option via SFP socket
- | Only 1 main switch port required per 8 channels
- | POE or POE Plus per channel, on all channels
- | Up to 300m on RG59, 400m on RG6, 500m on RG11
- | Automatic configuration for simple installation



Re-use of legacy cabling avoids business disruption in busy sites, such as airports, hotels and shopping malls

## A multi-channel rackmount solution for connecting and powering IP cameras over legacy coaxial cabling

The HIGHWIRE Powerstar product family offers high-speed Ethernet, reliable power delivery and long range over RG59, RG6 and RG11 coaxial cable. It is now available in an integrated 8-channel modular device for rackmounting, giving up to 32 channels in 1U, with space for an optional rear-mounted 1U PSU.

### Proven Technology

Veracity's HIGHWIRE technology has been proven in tens of thousands of installations over many years, delivering high-reliability full 100Base-TX Ethernet in all conditions. This offers consistent, predictable, IP video network performance even with today's high resolution HD and 4K IP cameras, delivering a full speed over 300m of RG59 cable, and 500m over RG11.

### Multi-Channel Rackmount Device

Base 8 integrates eight HIGHWIRE channels and a gigabit switch into a single device. It is specifically designed to allow rackmounting of up to four

devices in 1U, giving 32 channels per U. Veracity's unique 57V rackmounted POE power supply accessory can be mounted in the same 1U.

### Cost-effective Network Connection

The integration of a Gigabit switch reduces the number of main switch ports required to connect many IP video cameras. Thus each HIGHWIRE Powerstar Base 8 device requires only one main switch port, or 4 network ports for 32 channels. Each Base 8 device also has a rear-mounted SFP socket for an optional SFP fibre Ethernet module.

### Base and Camera Devices

In the diagram below, the HIGHWIRE Powerstar Base 8 device is connected to 8 legacy coaxial cable links. At the camera ends, there are single-channel HIGHWIRE Powerstar Camera devices connected to each link. The original analogue cameras are replaced by new IP cameras which are connected to HIGHWIRE Camera devices. The Base 8 device is powered by a Veracity 57V PSU and power is delivered up the coax to power the HIGHWIRE Camera devices which, in turn, power the IP cameras. See opposite page for POE power options and considerations.

### HIGHWIRE POWERSTAR BASE 8 INSTALLATION EXAMPLE

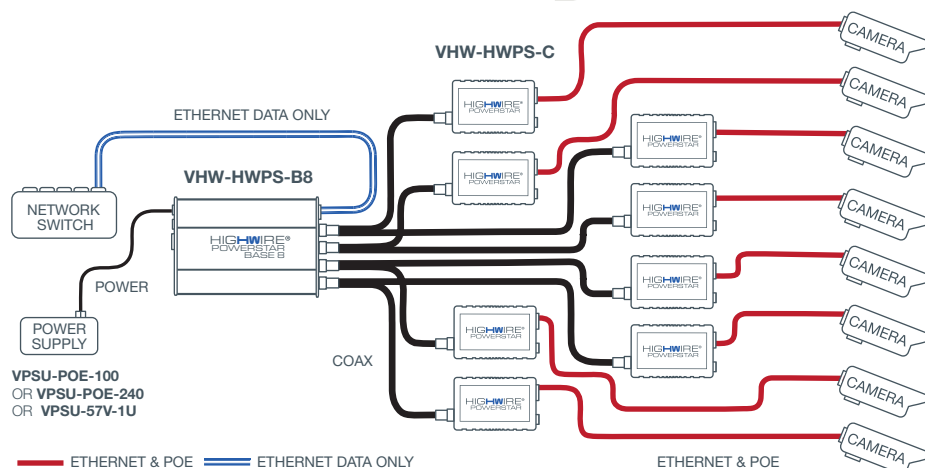

RACKMOUNT ETHERNET AND POWER OVER COAX SOLUTION



**Rackmount** | Four rackmounted HIGHWIRE Powerstar Base 8 devices assembled with a Veracity 1U PSU.



**Front** | 8 coax links with status LEDs, plus a Gigabit uplink port.

**Rear** | Power connectors (screw terminal or micro-fit) with SFP socket for fibre module.

**Simple Installation**  
 With no need to configure IP addresses, set DIP switches, or pair devices, installing HIGHWIRE Powerstar is straightforward. As soon as power is applied, the IP cameras will power up and their IP addresses will become available on the network. The zero configuration HIGHWIRE devices are completely network transparent.

**Multiple Channels per Coax**  
 Base 8 is compatible with Veracity's Powerstar Duo and Quad Camera devices, connecting multiple IP cameras over a single coax. For example, an obsolete analogue PTZ camera could

be replaced by four low-cost static IP cameras using a Powerstar Quad device.

**Power Supplies**  
 Veracity power supplies for POE are 57V DC or 56V DC devices, to provide the maximum power and distance possible within the POE standard (802.3af and 802.3at). Our 1U rack-mounted 57V 8.8A power supply is specifically designed for Veracity's IP Transmission products, including HIGHWIRE Base devices. The Base 8 rack mount kit can be assembled together with the 1U PSU to provide a complete power-and-32-channel-EOC\* solution in 1U.

**Redundant Power Supply Configuration**  
 Veracity's 1U POE power supplies are designed to allow redundant power configurations for maximum reliability. Pairs of devices (in 2U) may be cross linked with an optional cable assembly to allow full power to be delivered to the Base devices, even in the event of a failure of one of the power supplies.

**HIGHWIRE Product Range**  
 Powerstar Base devices are available in 1, 4 and 8-channel models. Powerstar Camera devices are available in 1, 2 and 4-channel models. Any Base model is compatible with any Camera model.

POE-OVER-COAX RANGE TABLE

RANGE TABLE	CAMERA POWER (watts)				
	5W	10W	15W	20W	25W
<b>RG11 (14AWG core)</b> <i>Copper Core</i>	500m 1640ft	500m 1640ft	500m 1640ft	500m 1640ft	500m 1640ft
<b>RG59 (22/20AWG core)</b> <i>Copper Core</i>	300m 1000ft	300m 1000ft	300m 1000ft	300m 1000ft	300m 1000ft
<b>RG59 (22AWG CCS)</b> <i>Copper coated steel</i>	270m 880ft	265m 870ft	185m 610ft	140m 460ft	110m 360ft

**POE-over-Coax™ Range**  
 HIGHWIRE Powerstar delivers reliable power at long range, even over low grade CCS cable. No setup is required and the coax connection is automatically established on power-up.

The table shows the range achievable by cable type and camera wattage.

## TECHNICAL SPECIFICATION

HIGHWIRE®  
POWERSTAR  
BASE 8

<b>HIGHWIRE INTERFACE</b>	
Connector type	BNC 75 ohm x 8
Cable type	Any 75 ohm coaxial (other impedances supported)
Range	Up to 300 metres [1000ft] on RG59 or 500 metres [1640 feet] on RG11 at full rate
Bandwidth	200 Mbps (total up + down) x 8
<b>ETHERNET INTERFACE</b>	
Connector type	RJ45 with optional SFP socket for fibre
Cable type	Cat5/6 Patch or crossover, auto-detected or as per optional SFP device
Rate	Gigabit Ethernet, Full duplex (1000Base-T) with auto-negotiation
<b>LEDS</b>	
Status indicators	HIGHWIRE coax link Ethernet link/activity (BASE) POE-over-coax See Quickstart Guide for LED indicator table and diagnostics. Guide also online
<b>POWER</b>	
Device power	10W rising to 20W under full POE load
POE Out	IEEE 802.3af (POE) or IEEE 802.3at (POE Plus) up to 25W per channel
Power input	57V DC, up to 6A via a 2-pin detachable screw terminal (supplied) or a 2-pin Micro-Fit power connector
<b>PHYSICAL/ENVIRONMENTAL</b>	
Dimensions	L 173mm (including BNC connectors) W 110mm H 40mm
Weight	572g [20.2oz]
Operating temperature	0°C to 40°C [32°F to 104°F]
Relative humidity	85% non-condensing
Compliance	FCC, CE, RoHS, REACH, UKCA, UL
<b>PRODUCT CODES</b>	
<b>VHW-HWPS-B8</b>	<b>HIGHWIRE Powerstar Base 8® - eight channel EOC base device (opt. rackmount)</b>
VHW-HWPS-B4	HIGHWIRE Powerstar Base 4® - four channel EOC base device
VHW-HWPS-C	HIGHWIRE Powerstar® single channel EOC adaptor for camera end
VHW-HWPS-C2	HIGHWIRE Powerstar Duo® - dual channel EOC adaptor for camera end
VHW-HWPS-C4	HIGHWIRE Powerstar Quad® - four channel EOC adaptor for camera end
VPSU-POE-100-UK/EU/US	100W, 57V DC power supply with power cable for UK, EU or US
VPSU-POE-240-UK/EU/US	240W, 56V DC power supply with power cable for UK, EU or US
VPSU-57V-1U-UK	57V DC, 8800mA (400W max) power supply, with cable for UK
VPSU-57V-1U-EU	57V DC, 8800mA (400W max) power supply, with cable for EU
VPSU-57V-1U-US	57V DC, 8800mA (350W max) power supply, with cable for US
	<i>For a full range of solutions, power supplies &amp; power configurations contact Sales at Veracity.</i>

\*EOC = Ethernet over Coax

© Veracity UK Ltd 2023. All rights reserved. DV1.9EN  
Under no circumstances should this document be reproduced,  
distributed or changed, partially or wholly, without written,  
formal authorisation from Veracity UK Ltd.  
HIGHWIRE®, HIGHWIRE Powerstar™, HIGHWIRE Powerstar  
Duo/Quad, HIGHWIRE Powerstar Base 8, Base 4,  
are trademarks of Veracity UK Ltd.

**Surge Protection**

All Veracity products have been independently tested to verify their resilience to the stringent immunity levels of international standards. Users should note that no electronic equipment can be guaranteed to be completely protected at levels beyond the defined standard; therefore product warranty cannot include damage to products which has been caused by surges exceeding those of the standards specified, for example lightning strike activity.

It is the user's responsibility to implement relevant surge protection measures, as appropriate to the installation. This may include the fitting of additional surge protection devices where required.



Veracity HQ  
Prestwick International Aerospace Park  
4 Dow Road  
Prestwick  
UK  
KA9 2TU

Tel +44 (0) 1292 264967  
www.veracityglobal.com  
sales@veracityglobal.com

See [www.veracityglobal.com](http://www.veracityglobal.com) website  
for country and region specific contacts.